

# INSTRUCTION MANUAL

## BS-10AF

### Fully Automatic Metal Cutting Band Saw (415V)

### 250 x 230mm (W x H) Rectangle

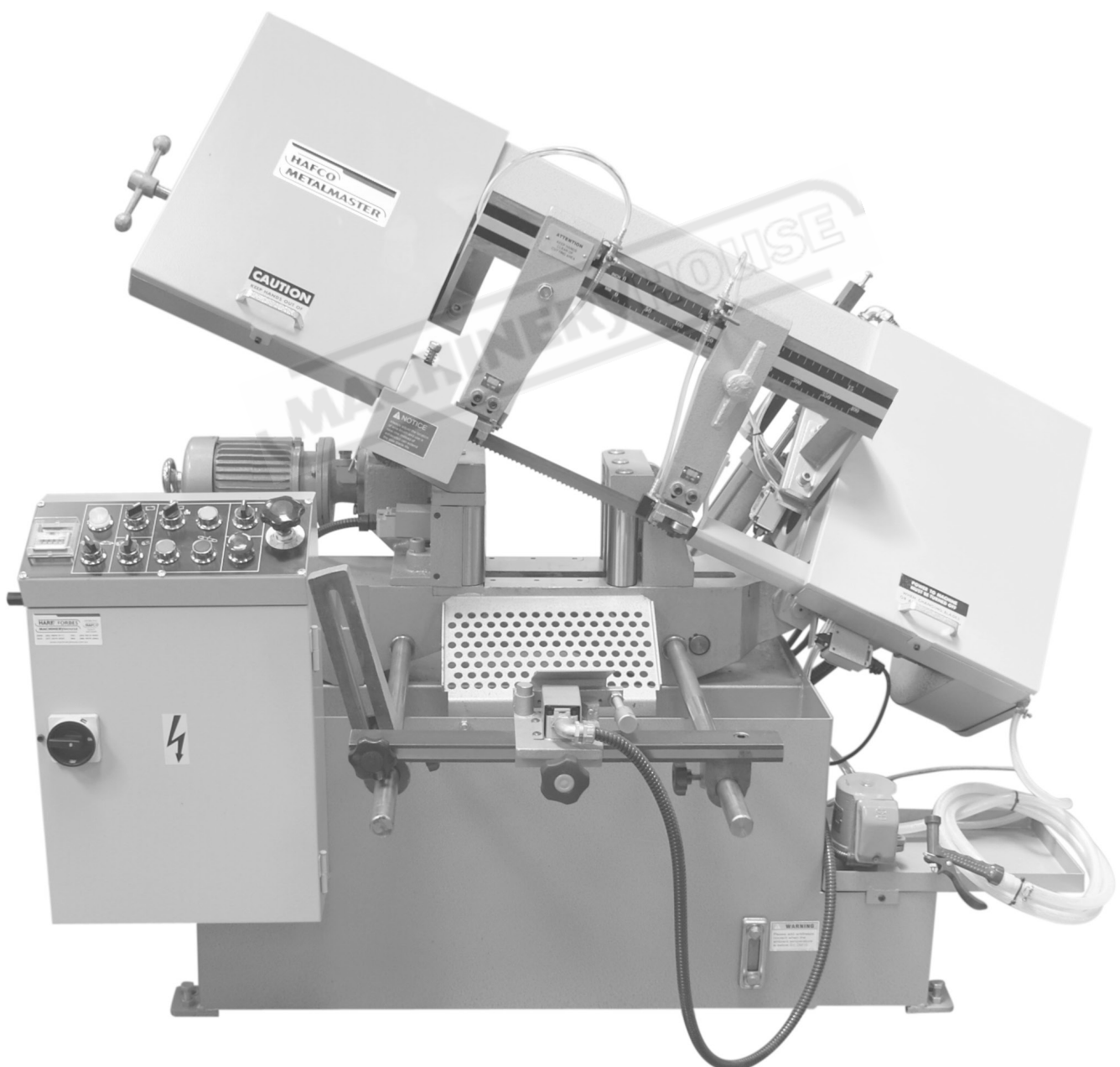



**B036**

## S A F E T Y

1. Know your bandsaw. Read the Operator's Manual carefully. Learn the operations, applications and limitations.
2. Use recommended accessories. Improper accessories may be hazardous.
3. Wear proper apparel.
4. Keep unnecessary people away.
5. Don't overreach or stand on tool.
6. Avoid dangerous environment. Don't use bandsaw in damp or wet locations. Keep work area well lighted.
7. Keep work area clean. Cluttered and slippery floors invite accidents.
8. Remove adjusting keys and wrenches from bandsaw before turning on power.
9. Avoid accidental starting. Make sure switch is off before plugging in power cord.
10. Don't force bandsaw. It is safe to operate at the cutting rate for which it was designed.
11. Never hand hold the material with saw in horizontal position. Always use the vise, clamp securely.
12. Keep belt guard and wheel covers in place and in working order.
13. Support long, heavy work from the floor.
14. Always remember to switch off the machine when the work is completed.
15. Disconnect power cord before adjusting, servicing and changing blade.
16. Check damaged parts. Damaged parts must be replaced or repaired.
17. Moving parts should keep in alignment. All adjustments are to be made with power disconnected.
18. Use a sharp blade and keep tool clean for best and safest performance.
19. Safety is a combination of operator's common sense and alertness at all times when the saw is functioning.
20. Keeping the bandsaw in top condition is essential for safety.

## SPECIFICATION

MAX CAPACITY	 mm	230 ( 9" )		
	 mm	230x250 (9"x10")		
CUTTING SPEED RANGE	m/min.	60Hz	24 - 90	( 80 - 300 fpm)
		50Hz	20 - 75	( 67 - 250 fpm)
MOTOR OUTPUT	kw	SAW BLADE	1.125	
		HYDRAULIC	0.18	
		COOLANT	0.1	
BLADE SIZE	mm	3353x25x0.9 ( 11'x1"x0.035" )		
HEIGHT OF WORK BED	mm	650 ( 25.5" )		
WEIGHT	kg	450 (995 LBS)		
FLOOR SPACE	mm	LENGTH	1600 (63")	
		WIDTH	710 (28")	
		HEIGHT	1080 (42.5")	
STANDARD ACCESSORIES	Hexagon wrench		one set (1.5mm-10mm)	
	Blade		One piece	
	Brush		One piece	
	Material stop		One piece	
	Electric system		One unit	
	Complete coolant system		One unit	
	Operation manual and parts list		One copy	

CONTROL PANEL

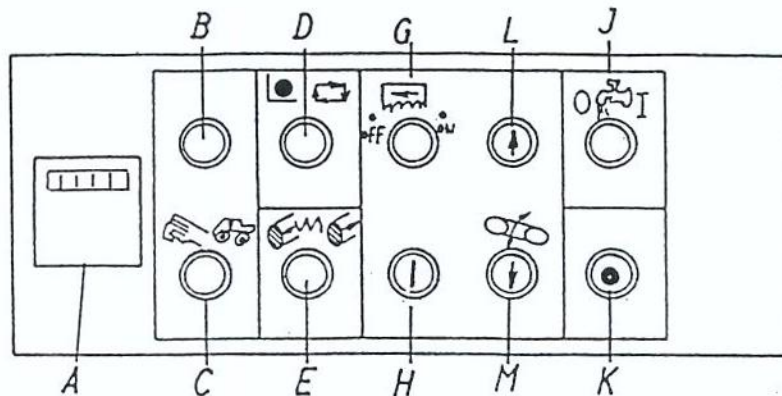

**A** : Electromagnetic predetermining counter, method of counting : Addition  
 Operation: See separate instruction

**B** : Pilot lamp: Illuminates only with selector switch

**C** in  position

**C** : Selector switch

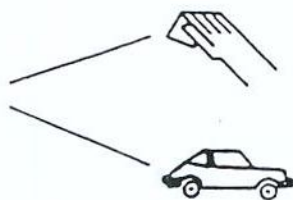

Manual

Automatic

**D** : Selector switch

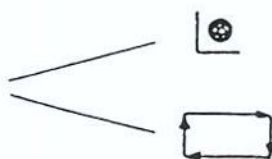

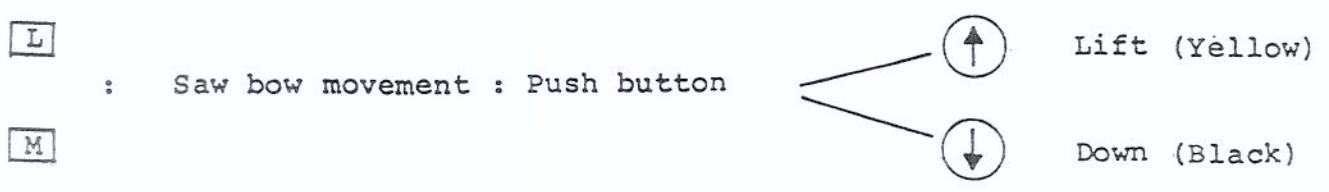
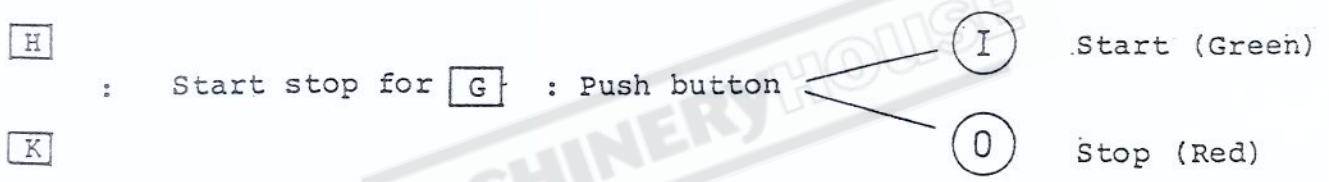
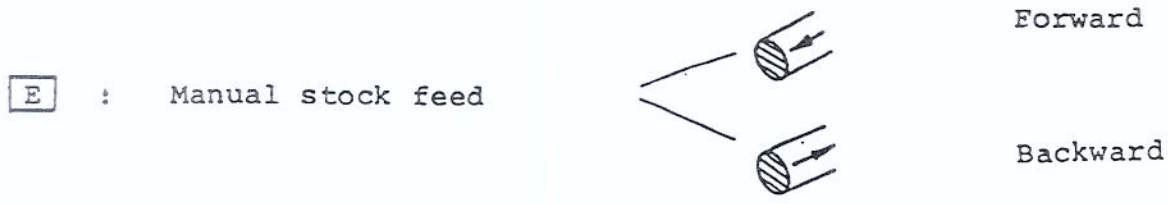

Band change

Automatic cycle



## INSTALLATION

### 1. Electrical Hook Up

- a) Loosen screws on top of door, flap down door to which the electrical controls are mounted Connect power to terminals R-S-T (L1,L2,L3) also a neutral terminal is provided.
- b) Set main switch to "On" position-this will be indicated by the pilot lamp on the control panel.
- c) Set selector "D" to "Band Change" position.
- d) To start the saw drive motor set selector switch "G" to  +  -saw drive motor starts, then depress push button "H" to start motor.
- e) Lift hinged door of drive wheel and check that wheel is rotating in line with red arrow. Should the wheel turn anti-clockwise turn off power and change over two phases at terminals.
- f) For stopping saw drive motor depress push button "K".

### 2. Fitting of Saw Band (Band Width 25mm = 1" only)

- a) Turn feed valve to "O" position.
- b) Push button "L" for up-movement of saw bow, push button "M" and "K" to shut off hydraulic pump when saw bow has been lifted by one half approximately.
- c) Place saw band over wheels. It might be necessary to move back the idler wheel with toggle. Tension the saw band until it no longer slips of the wheels.
- d) Insert band between saw guide rollers. The eccentric bolts of both guides are pre adjusted to operate with 0,9mm (035") thick saw bands.  
In case of wrong tooth face direction take off blade and twist band inside out.

New bands have to be retensioned frequently as they will stretch slightly at the beginning.

## OPERATING FEATURES

The COSENAH-1010 offers an automatic cycle, controlled by hydraulic, electric and mechanic devices.

A sensitive hydraulic system controls the lifting and lowering of the saw bow and includes an automatic feed control valve. This unit is activated by the back of the saw band itself and is designed to give maximum performance and life to the saw band. Its operation is simple and effective. It helps to prevent overloading of the saw teeth, eliminates clogging and ensures that each and every piece is cut accurately.

The push button control panel is mounted on the top of the saw bow and there is an extra control cabinet with the electrical controls mounted to a flap out door at the rear lower part of the machine. The AH-1010 has each one motor for the saw drive, hydraulic pump and stock feeding.

### 1. Control Panel

All controls are located at the top of saw frame on the control panel.

#### A) Electric Impulse Counter

##### a) Preselection

Depress the reset push button and simultaneously depress the flap downward by its edge under the figure window to open the flap. Set the desired number of pieces to be cut by finger rotate the gears with each figure wheel. Close the flap by pulling its edge upward.

Note: Counter functions in both "manual" and "automatic" mode, and only with the flap closed.

##### b) Resetting

Depress reset push button of the counter. Since the counting operation functions with the lifting motion of the saw bow, it is important to carry out the preselection and resetting when the saw bow is at its lifted position.

The saw bow will rest at its lowest position and the motors will stop after the preselected number of pieces to be cut has been reached. To lift saw bow for further setting and cutting, first depress the reset push button of the counter and depress push button "H" to start the motors, then depress push button "L" to lift saw bow. Reset the counter when saw bow is at lifted position before further setting and cutting.

#### B) Selector Switch with Indicating Lamp

a) Semi-Automatic operation

It might be necessary to use the machine for single cuts without automatic feeding. Selector switch "C" must be set to "manual" position, the stock either be fed against the stop with manual stock feed selector "E" or adjusted to length by manually rotate the handwheel mounted coaxial with the feed motor.

The semi-automatic cycle only assures lifting of saw bow after each cut, down feed of saw bow must be activated by manually depress the push button "M". The saw bow down feed rate is controlled by the feed valve on the right guide arm. If one prefer to keep saw bow at lifting position, turn feed valve to "0" setting before lifting saw bow, then depress push button "M" after saw bow has reached the upper limit switch.

Note: Always depress push button "M" to release the lifting pressure in the hydraulic system after saw bow has reached the upper limit switch. When using selector switch "E" to feed the stock, be sure that the saw bow had touched the upper limit switch or the selector switch will not function when turn to "Forward" direction.

b) Automatic cycle

The automatic cycle is recommended starting with four or five equal cuts. Set switch "C" to "Auto". The end limit switch on the stop bar triggers the down movement of the saw bow. After the cut has been completed, the lower end limit switch will start the lifting of the saw bow, having reached the upper position the upper end limit switch will start the feeding of the stock against the switch of the material stop. At the moment the stock touches against the stock feed end limit switch, the feeding motion will be stopped and the down movement of the saw bow begins. This cycle will be repeated after each cut.

During automatic operation the lamp "B" will indicate that the machine works with automatic cycle.

Proper feed rate of saw bow must be selected from the feed valve before operation.

2. SAFETY SWITCH stops machine should a band break

a. Function

Selector switch set to "AUTO CYCLE" = saw band must be tensioned to operate machine

All motors will be stopped automatically in case of band breakage.

b. Machine will not start

a) without saw band mounted and selector switch in

- "AUTO-CYCLE" position.
- b). should saw band not be correctly tensioned.
  - c) after band breakage
  - c. In case of band breakage
    - a) set selector switch to "BAND CHANGE" position
    - b) start hydraulic pump
    - c) press button for saw bow lift
    - d) replace saw band, tension correctly
    - e) set selector switch to "AUTO CYCLE"

Attention: The machine can be operated in "BAND CHANGE" position, however, the safety stop then is disengaged.

### 3. Coolant System

The lower part of the base serves as coolant tank. The cutting fluid is supplied to the saw guides and should be mixed in accordance with the recommendations of the supplier. It should not contain too much grease to avoid slipping of the saw blade on the wheel.

Never work with pure water only!

For cleaning of the tank take off discharge table and steel sheet cover.

Tank capacity approx. 55ℓ - approx. 15US gal = approx 12 British gal.

### 4. Material Stop and Stock Clamping Device

- a) Material stop loosen setscrews (located on the bottom of the bed) of the two stop bars, pull out bars until they are flush with the rear machine bed, fasten setscrews, and put stock between roller vice.
- b) Clamping device (roller vice): tension with hand wheel until the space between the cup springs is reduced by one half approximately, however, the stock diameter also influences the amount of tensioning. This is a matter of experience.
- c) Set selector switch "C" to "MANUAL".



With selector switch "E", jog stock to cut-off length required.



- d) Now push end limit switch onto the material, the pin of the end limit switch mechanism should touch the material at its upper utmost right hand side to ensure that the sawn off piece can fall down freely. Also be sure that

all clamping wheels and levers of the stop mechanism are clamped tightly.

- e) The guide arms or guides must never touch the stock but should be set as close as possible to the stock to be sawn. Be sure that the guide arms are clamped tightly to the dove-tailed guide rail with the help of the clamping grip.
- f) The upper end limit switch can be adjusted in accordance of stock's height. The adjustment of this switch should guaranty that the up-movement of the saw bow is stopped just above the material.

MACHINERYHOUSE

## MAINTENANCE

### Daily:

- A) Remove chips from upper blade guard and between feeding rollers, clean movable parts of end limit switch and the space around the saw wheels.

### Weekly:

- A) Saw guide rollers, saw guide inserts and wheel brush must be checked.

- 1. Guide rollers:

Clean with a brush, defective guide rollers must be replaced immediately, also replace worn out thrust rollers. Adjust hydraulic regulating valve to position "0", then check easy up and down movement of bolt. For lubrication of this bolt use oil, do not take grease which may harden and create malfunction of this bolt.

- 2. Guide inserts:

The carbide face of the inserts should always be in good order, it might be necessary to regrind the guide inserts or to replace them from time to time.

- 3. Blade cleaning brush:

If set too close to the saw band, the brush will wear quickly. However be sure that the brush cleans the saw teeth thoroughly. Worn out brushes must be replaced immediately.

- B) Check amount of coolant liquid as there is a constant loss of coolant during productive cutting (protection sheets above coolant tank can be removed). For refilling be sure to mix coolant conforming to recommendation of the coolant supplier, do not fill in pure water only.

### Monthly:

- A) Clean coolant tank, check and clean coolant suction filter
- B) Clean insides of pulleys, check V-belt
- C) On the feeding device check chain for correct tension. Take off cover unscrew the setscrew located on the front of the vice housing, then adjust the eccentric bolt with a pin for proper tensioning of the chain.
- D) Clean feeding rollers with crude oil.
- D) Clean the rims of the saw wheels carrying the saw band.

### Miscellaneous

- A) Electrical system of the machine needs no maintenance.
- B) Should the machine be operated out of doors or in rooms without heating, do not forget to add an antifreezing solution to the coolant in winter and according to the instruction of the coolant supplier.

## Some Words about the Bandsawing Blades

The COSEN cut-off saws are designed to apply high quality high speed steel saw bands. To utilize the sawing potential and productivity of high speed steel saw bands our machine must be of rugged design, have the right type of saw guides, have enough motor power and band speed, must be able to apply the necessary tension to the band. Your COSEN saw has all these features.

The saw band is guided through its cutting by roller guides, to take the flex out of the blade as it comes off the wheels and precision carbide insert guides hold the bands securely and guide accurately through the cut. In addition thrust rollers are provided. The saw tensioning device in conjunction with the strong hollow cast saw bow guarantees adequate band tension.

To make full use of good quality and high speed saw bands a strong motor is being required, hydraulic automatic regulation of cutting feed and pressure together with positive hydraulic downfeed.

Band life is influenced by several factors such as type of stock to be sawn, hardness, band speed, cutting pressure, type of coolant, correct saw pitch related to stock diameter, tooth shape and last not least by the ability of the saw operator.

### High Speed Steel Saw Bands:

Recommended for cutting "tough to machine" materials, for economic production sawing, especially for use on automatic machines.

### Saw Bands of Special Steel:

May be used for not so tough to machine materials and if a better cutting rate is required when cutting standard steels.

### Carbon Steel Saw Bands:

Suitable for general use on easy to machine stock and for single cuts.

### Some cutting rates (approx.):

	CS-Band	Special-Band	HSS-Band
Free cutting steel	ab. 3-4 sq. inch ab. 20-25 cm <sup>2</sup> /min	4-6 sq. inch 25-40 cm <sup>2</sup> /min	10-16 sq. inch/min 70-100 cm <sup>2</sup> /min
C45 (AISI C1040) (970EN4 3B)	2,5-3 sq. inch 16-20 cm <sup>2</sup> /min	3-4 sq. inch 20-25 cm <sup>2</sup> /min	9,5-13 sq. inch/min 60-80 cm <sup>2</sup> /min
V2A (AISI 302) High Chrom.-High Nickel	not to be recommended	1,2-2,5 sq. inch 8-15 cm <sup>2</sup> /min	2,5-4 sq. inch/min 15-25 cm <sup>2</sup> /min
V4A (AISI 316) High Chr.-Ni with Molybdenum	not to be recommended	not to be recommended	1,3-1,8 sq. inch/min 8-12 cm <sup>2</sup> /min

The approximate rates refer to cut-off saws with 2 HP saw drive motors and band speed up to 180 m/min (600 FPM) Figures shown must be reduced by 20-30% when using machine of less HP and max. band speed up to 60 m/min (200 fpm) only.

### Tooth Forms:



Standard (precision)



Skip-a-tooth



CLAW-tooth

#### Standard:

This tooth design is most often used for general metal cutting, available with a saw pitch of 4-22 TPI, for cutting of solid stock and structurals, cutting of steel, cast iron, hard non-ferrous metals – smooth surface finish.

#### Skip tooth:

Designed for cutting soft sticky materials that have a tendency to clog. The teeth are spaced further apart and the gullet is deeper to give large chip-clearance. Suitable for sawing larger stock diameter – good surface finish.

#### Claw tooth:

For cutting of larger stock of ferrous and non-ferrous metals, for faster cutting – coarse surface finish.

### Saw set:

#### Standard (Raker):



for general purpose metal cutting applications

#### Wave set:



recommended for cutting light sections in metals such as sheet, tubing and smaller solids, generally used on fine pitch blades

#### Alternative set:



the teeth are set alternatively right and left, this type of set is generally used to give faster cutting of soft steels, aluminium, etc.

**Rule of the Thumb:**

- The thinner the stock, the finer the saw pitch
- The thicker the stock, the coarser the saw pitch
- The more difficult the stock, the finer the saw pitch
- The softer the material, the coarser the saw pitch

At least three teeth always must be in contact with the material being cut.

**Solid stock:**

up to 25 mm	-	1"	8-10 TPI	
25-100 mm	-	1"-4"	6- 8 TPI	
100-250 mm	-	4-10"	3- 4 TPI	

**Structurals:**

up to 10 mm	-	3/8"	10- 8 TPI	
10-20 mm	-	3/8-3/4"	8-10 TPI	
above 20 mm	-	3/4"	6- 8 TPI	

**Solid:**

up to 20 mm	-	3/4"	8-10 TPI	
20-80 mm	-	3/4-3.1/4"	2- 8 TPI	
above 80 mm	-	3.1/4"	4- 6 TPI	

(per unit)

**Sawing Practices:**

**Correct**

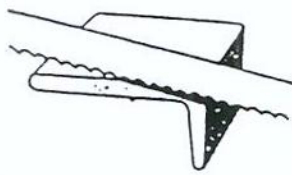

Several teeth contact work

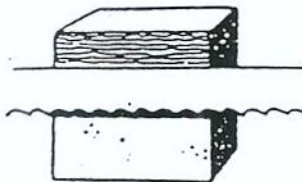

Coarse teeth clear chips freely

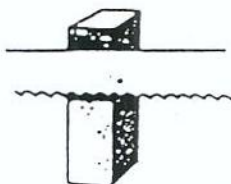

Three or more teeth on cutting wall

**Incorrect**



Teeth strike sharp edge

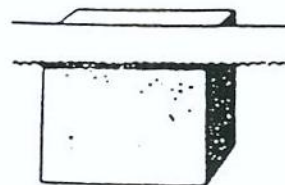

Teeth too fine for large solids

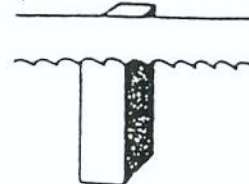

Coarse teeth rip on thin wall

## ADJUSTMENTS

**WARNING** ALWAYS DISCONNECT POWER CORD WHEN MAKING ANY ADJUSTMENTS.

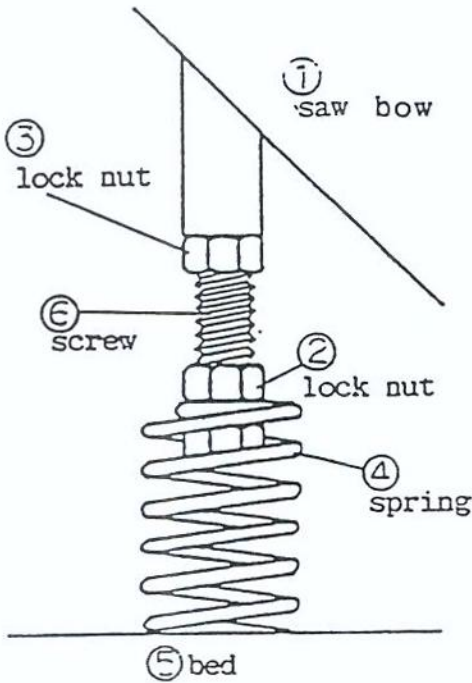

(Fig 10)

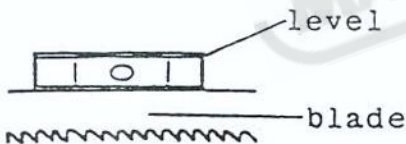

(Fig 10-A)

## HORIZONTAL STOP SPRING CUSHION

1. Place a level on the bed (Fig 10-5) to obtain the levelling.
2. Loosen the lock nut (Fig 10-3), and lower down the saw bow, then place the level on the top of saw blade (Fig 10-A) to set levelling against bed horizontal line by adjusting the screw (Fig 10-6).
3. Tighten the lock nut (Fig 10-3) when levelling is obtained.

**NOTE** If the saw blade top line is not levelling against the bed horizontal line, the workpiece of material can not be cut off thoroughly.

## AUTOMATIC SHUT-OFF

The motor should shut off immediately after the blade has cut through the material and just before the head comes to rest on the horizontal stop spring cushion.

If it does not, the spring cushion must be adjusted.

1. Check adjustment of horizontal stop spring cushion. Refer to "horizontal stop spring cushion adjustments".
2. Raise head, and push switch button to "ON" position. Lower head slowly and observe actuation of switch mechanism.

## BLADE TENSION

Turn Blade Tension Hand Wheel ( 1-65 ) clockwise to increase blade tension. Tension should be just enough that Blade does not slip on Drive Wheel while cutting. Do not apply excessive tension.

Some of the uncommon problems may be encountered in band saw are described here with recommendation for correcting them.

## 1. Vibration on Saw Bow

- A. Cause (1): Dull blade or stripped blade  
Remedy: Replace a new saw blade.

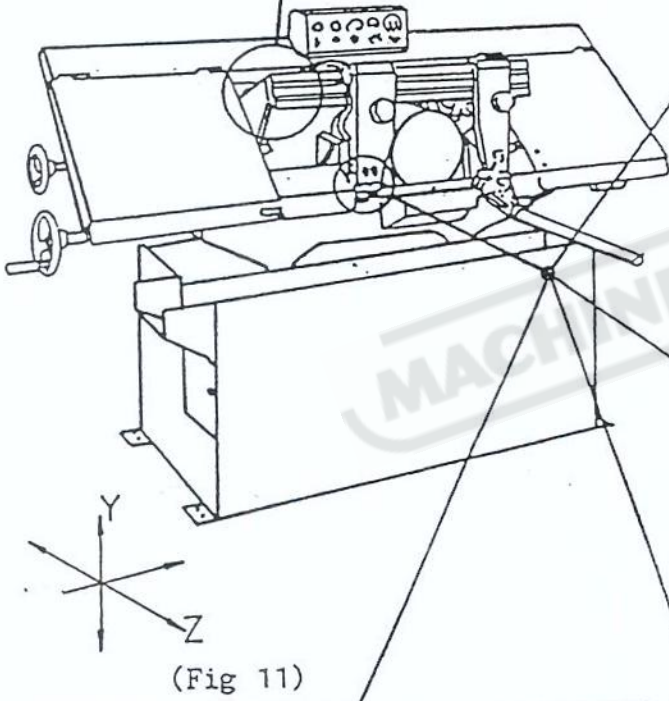
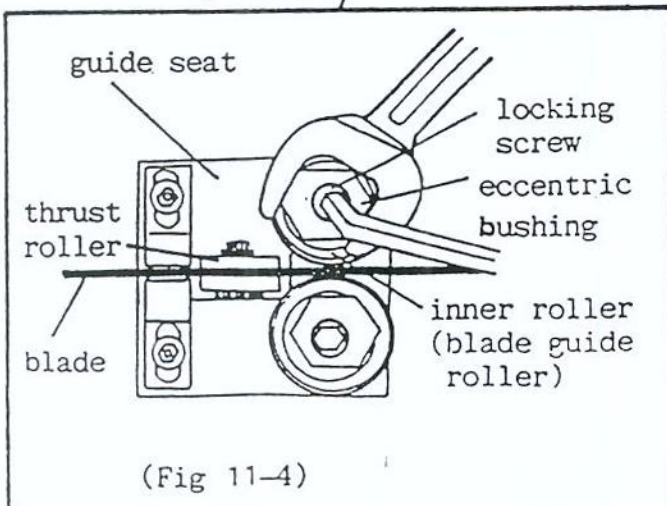
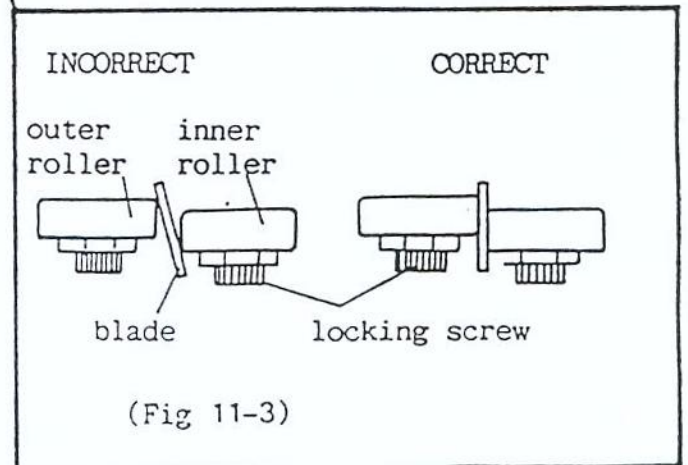
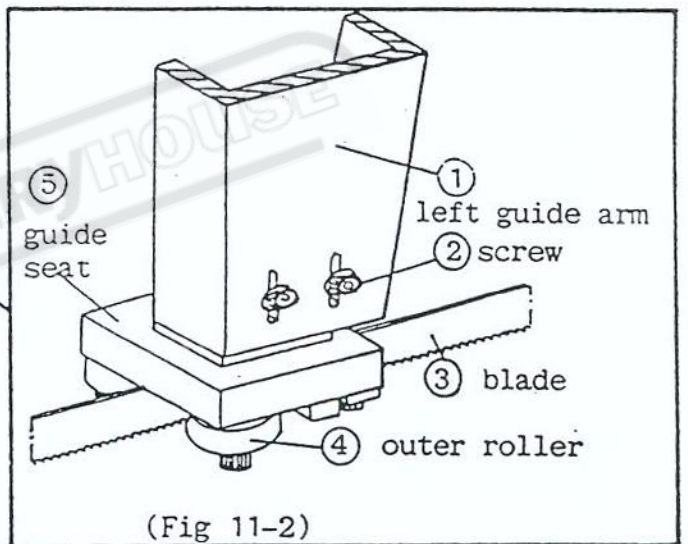
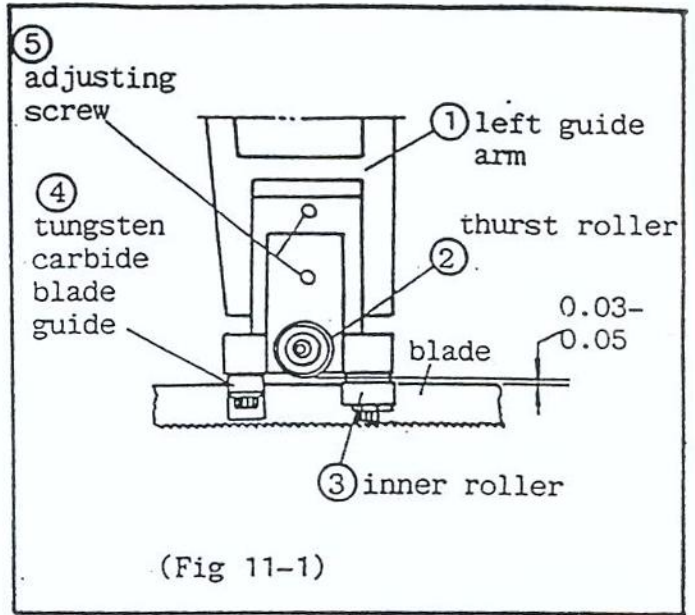
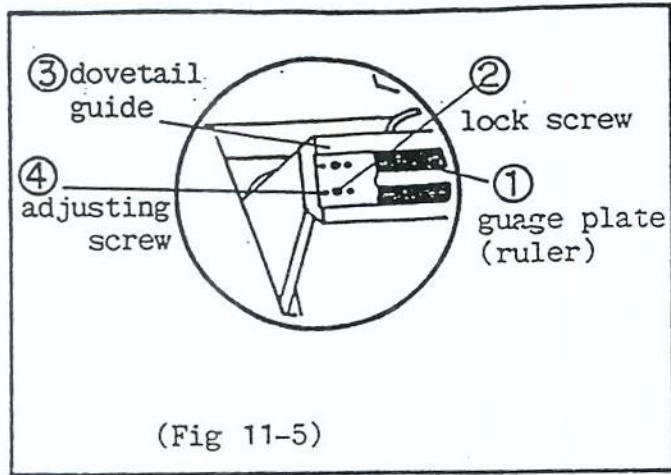

B. Cause (2): Too large clearance between saw blade and thrust roller (Fig 11-1-(2)).

- Remedy: a. Loosen the two screws (Fig 11-2-(2)).  
 b. Move guide seat (Fig 11-2-(5)) downward to adjust the clearance of 0.03-0.05mm between thrust roller (fig 11-1-2) and saw blade.  
 c. Re-fasten the two screws (Fig 11-2-(2)).

2. An improper slant downward Y axis (Fig 11) cut-off work.

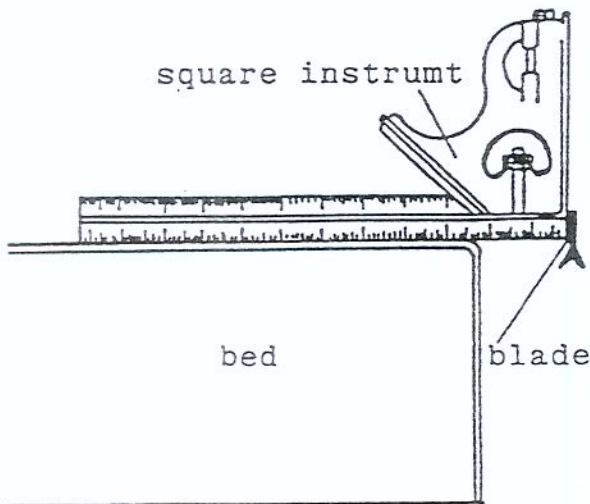

(Fig 12)

A. Cause(1): Improper blade tension.  
 Remedy: Consult blade tension (P.11)

B. Cause (2): Incorrect alignment between rollers (outer; inner) and saw blade (Fig 11-3, left).

C. Remedy: a. Loosen the tungsten carbide blade guide (Fig 11-1-(4)),  
 b. Loosen locking screws (Fig 11-4) by hex wrench.  
 c. Adjust eccentric bushing (Fig 11-4) by a spanner to make saw blade 90° against bed surface (Fig 12).

D. After finishing the adjustment, tighten the locking screws (Fig 11-4), and make sure the face of tungsten carbide blade guide contacts completely against alongside the saw blade (Fig 11-1-(4)).

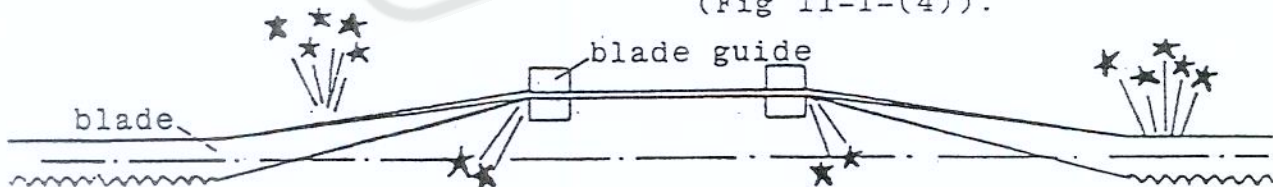

INCORRECT (Fig 13)

**CAUTION** The adjusting screw (Fig 11-1-(5)) is factory-fixed. Please do not try to adjust it unless the machine is seriously impacted by an accident as to lost the accuracy.

**NOTE** After finishing all the adjustment, be sure to double check the saw blade must not be in twisted condition. (Fig 13)

3. An improper tilt inward or toward X axis (Fig 11) cut-off work.

Cause: Incorrect alignment between fixed vise jaw and saw blade.  
 Remedy: Adjust the vise 90° against saw blade. (consult page 9, Fig 7).

4. Fig 11-5

The dovetail guide is factory accurately fixed. Please do not try to adjust it unless the machine is seriously impacted by an accident. If adjustment is necessary, please follow the procedures.

- (1) Take off the arm guides.
- (2) Take off the guage plate (which is adhered to dovetail with glue), you will find there are 4 adjusting screws on each end of left and right side.
- (3) Replace the arm guides.
- (4) Make fine adjustment on these adjusting screws.

## MAINTENANCE

**WARNING** ALWAYS DISCOUNNECT POWER CORD WHEN PERFORMING ANY MAINTENANCE. Keep the Band Saw and Motor clean, frequently blow out any chips or dust.

## LUBRICATION

All ball bearings are permanently lubricated and sealed. They require no further lubrication (except pivot hole).

The Gear Box lubricant does not have to be changed unless it becomes contaminated. Normally, after 300 hrs. of primary operation, drain away the oil and clean the internal of the machine, then put in new oil. Do so hereafter every 2500 hrs. of operation.

LUBRICANT: 90 MOBIC OR THE EQUIVALENT

To check "transmission-lubricant-level" place head in horizontal position and allow unit to set a few minutes to allow oil to drain down.

All other moving parts should be lubricated regularly to insure ease of operation. Use Light Machine Oil.

## TROUBLE SHOOTING (mechanic troubles)

1. Blade sliding down:  
(1) (2) (3) (4) (5)
  2. Blade running hard on wheel flange (saw back gets defective or screaming noise)  
(1) (3) (5)
  3. Blade swings sideways (vibrates)  
(2) (6) (7) (9) (10) (11) (12) (1)
  4. Teeth stripping  
(9) (13) (14) (15) (16) (17) (18) (19) (20)  
(21)
  5. Saw slips on wheels  
(1) (2) (17) (18) (22) (23) (27)
  6. Poor cutting rate  
(8) (16) (18) (20) (23) (26) (29) (54) (61)
  7. Blade cuts out of true
    - a. Related to stock  
(30) (31) (32) (33)
    - b. Cutting surface is slanted outwards or inwards  
(10) (11) (17) (18) (21) (23) (34) (35)
  8. Premature dulling of teeth  
(6) (17) (20) (36) (37) (38)
  9. Premature saw band breakage  
(1) (4) (6) (17) (18) (34) (36) (39)
  10. Saw teeth are clogged  
(15) (16) (17) (18) (41)
  11. Surface finish too rough  
(10) (17) (18) (21) (34) (38)
  12. Unacceptable length tolerances on cut-off pieces:  
(24) (30) (32) (43) (44) (42)
  13. Cutting rate drops  
(23) (46) (2) (48)
  14. Machine chatters  
(21) (48)
  15. Coolant pump does not provide coolant  
(25)
  16. Hydraulic Troubles
    - 16/1 Teeth stripping
    - 16/2 Poor cutting rate
    - 16/3 Blade cuts out of true
    - 16/4 Premature dulling of blade
    - 16/5 Premature breaking of blade
    - 16/6 Surface finish too rough
    - 16/7 Machine chattering  
(21)
  17. Slow raise of saw bow:  
(50) (51) (61)
  18. Saw bow will not raise:  
(50) (51) (53) (60) (61)
  19. No down movement of saw bow:  
(54)
  20. Saw frame moves down too slowly:  
(51) (55) (56)
  21. Saw frame moves down too fast:  
(21) (51) (57)
- Electrical Troubles
22. Saw bow does not raise and does not go down:  
(58) (59)
  23. Although machine is switched on it does not start:  
(60)
  24. One or several motors will not start:  
(62)

## REMEDY :

- (1) Clean wheel flange with scraper.
- (2) Retension saw band.
- (3) Check back of saw band for straightness especially on weld joint.
- (4) Loosen guide inserts 5019-18 and adjust eccentric bolt 5019-6 after loosening of hex screws to allow smooth run of band between guide rollers 5019-7, retension hex screw and re-adjust guide inserts.  
You must be able to move up and down saw band between guide rollers easily and furthermore band must not be clamped tight between guide inserts.
- (5) Check saw wheels for play.
- (6) Change to finer pitch of blade
- (7) Increase or reduce band speed.
- (8) Increase cutting pressure.
- (9) Stock not clamped correctly.
- (10) Check condition of side rollers 5019-7, thrust rollers 5019-11 and the guide inserts 5019-18.
- (11) Retension saw band.
- (12) Adjust both guides closer to stock or guides may be adjusted too close.
- (13) Change to finer pitch for thin profiles.
- (14) Change to coarser pitch for solid stock.
- (15) Check blade cleaning brush, replace if necessary.
- (16) Use coolant that avoids clogging of saw teeth (for instance CIMCOOL, ADDICUT).
- (17) Reduce cutting pressure.
- (18) Increase band speed.
- (19) Ensure that on initial setting of saw bow feed rate, especially on rectangular sections, the feed rate should be low at first position 1 of feed valve.
- (20) Saw band quality not suitable for stock to be cut.
- (21) Carry out regulating valve function test.
- (22) Saw band is struck in stock, lift saw bow and refeed.
- (23) Replace dull saw band.
- (24) Retension chain of feeding device.
- (25) Take out suction filter, fill in water with main motor running.
- (26) For sawing of mild and semi hard steel use saw band with coarser pitch.
- (27) Coolant too greasy.
- (28) Stop cock is not opened entirely.
- (29) In works, the cutting pressure has been adjusted to approx. 30kg. You can increase this down pressure by turning the knurled nut on top of feed regulating valve to left hand, however by doing so, you will reduce the sensitivity of the automatic regulation of cutting pressure.
- (30) The stock to be cut is not straight.
- (31) Check right angle setting of vice clamps in relation to saw band.
- (32) Check parallel position of stock to machine bed.
- (33) Machine bed must be in level both longitudinally and transversely.
- (34) Check TPI and tooth form.
- (35) Adjust guides closer to stock.
- (36) Reduce band speed and cutting pressure for new saw bands and for the first two or three cuts. This especially is true for new high speed steel saw bands.
- (37) Reduce band speed.
- (38) Increase coolant flow.
- (39) Should blade break at weld, the weld was defective or incorrect, replace band or reweld, use butt welder if possible.

- (40) Increase or reduce band tension.
- (41) Use coarser pitch, check tooth form.
- (42) Retension all handles, wheels, levers on material stop mechanism.
- (43) Adjust contact in end limit switch to allow earlier stopping of feeding device when cutting large diameter stock to avoid hard pushing of stock against stop lever.
- (44) Surface of stock is rough and irregular, not all owing a smooth saw feed. It might be possible that the end limit switch stops the feeding motion before the full cut-off length is reached. Re-adjust end limit switch on fine adjustment screw or on the contacts.
- (45) Check V-belt, clean or replace.
- (46) Check V belt tension.
- (48) Take off saw band, turn the drive wheel, there must be no play. Should there be no play:
  - a. Check the keys replace if necessary.
  - b. Check worm wheel, replace if necessary.
- (49) Loosen nut on piston of hydraulic cylinder, it must be possible to lift saw bow by hand easily. Should this be difficult, grease bearings of pivot shaft and bolts of piston and check piston for smooth up and down movement.
- (50) Replace piston in hydraulic cylinder.
- (51) Check all hydraulic lines and connections for tightness and sharp bends.
- (52) Check oil level in oil tank.
- (53) Loosen lower hydraulic line on feed valve. Should hydraulic oil not flow out, clean feed valve and stop cock.
- (54) Stop valve should be opened fully.
- (55) Between pressure pin of the valve and the adjusting screw of bolt of right saw guide, there should be a play of 0,4mm (1/64").
- (56) Non return valve of 4-way valve "C" should be cleaned or replaced.
- (57) Solenoids of 4-way valve are disconnected from power supply, magnetic contactors do not work, replace coils of magnetic contactors.
- (58) Replace solenoid of 4-way valve, be sure to have power income cut-off when replacing.
- (59) Knurled nut on hydraulic valve may be turned clockwise to increase down pressure which has been set in works to 30kg. Through increasing the cutting pressure the sensitivity of the automatic pressure regulation of course will be diminished.
- (60) Electric counter has shut off.
- (61) The hydraulic pump delivers a max, pressure of appr. 16 kg/cm<sup>2</sup> (230p.s.i.) The pressure can be adjusted on the maximum pressure valve B after taking off the cap and loosening of the counter nut. Should no pressure adjustment be possible with help of this valve, check cap seal in hydraulic pump, replace if necessary. The saw bow must lift swiftly.
- (62) The magnetic contactors have cut the power supply. Open door of switch box and push in reset buttons, check the fuses.

1. SAW BOW

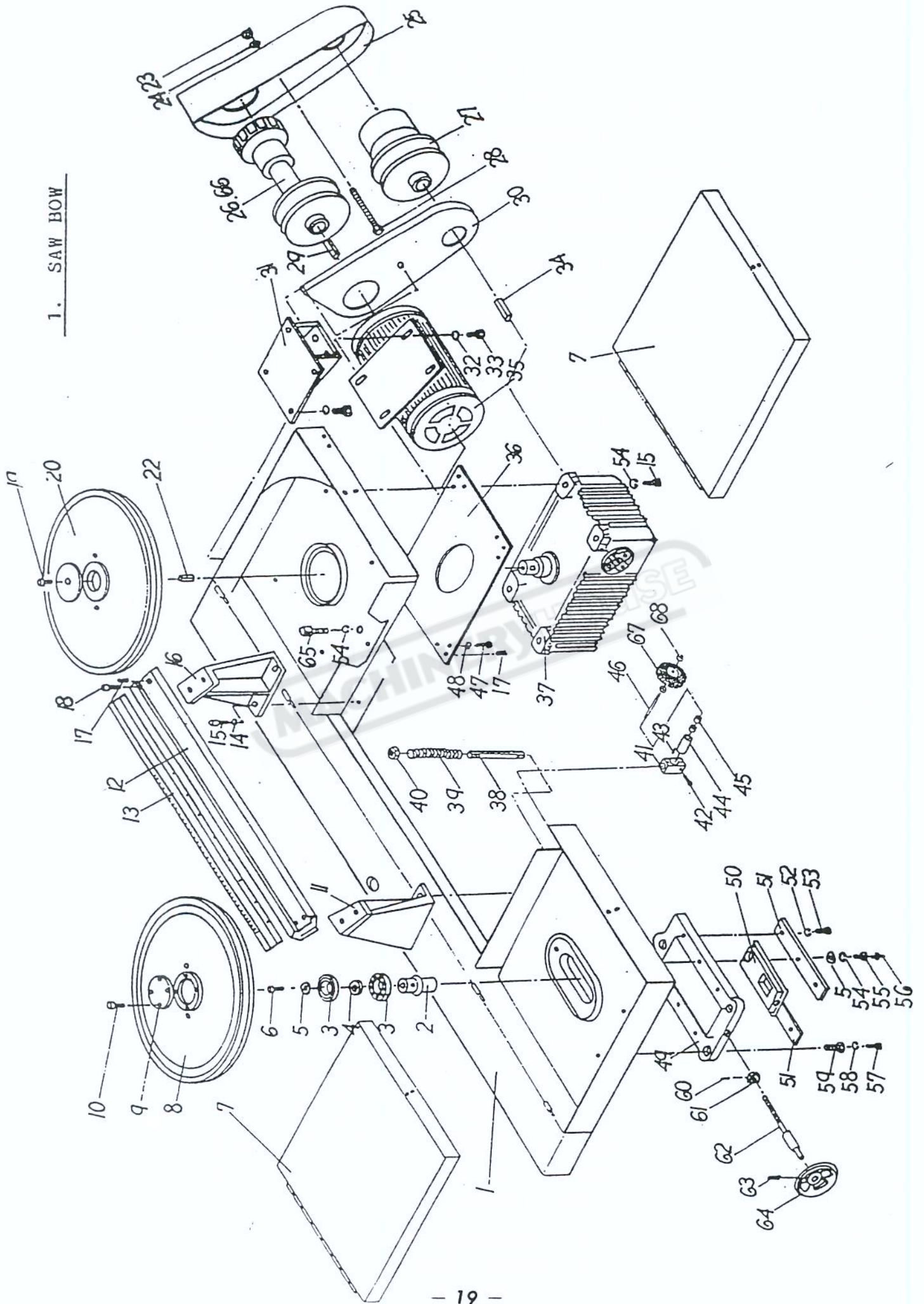

## 1. SAW BOW (A)

Index No.	Parts Name	Type	Q'ty	Note
1-1	Saw bow		1	
1-2	Idle wheel shaft		1	
1-3	Bearing	6205Z	2	
1-4	Bearing washer		1	
1-5	Washer	1/2	1	
1-6	Bolt		1	
1-7	Wheel cover		2	
1-8	Idle wheel		1	
1-9	Washer (A)		1	
1-10	Screw	1/4-20UNCx1/4	4	
1-11	Bracket (left)		1	
1-12	Dovetail guide		1	
1-13	Guage plate (ruler)		1	
1-14	Spring washer	1/2	4	
1-15	Bolt	1/2-W12x1 1/4	8	
1-16	Bracket (right)		1	
1-17	Set screw	5/16-18UNCx3/4	8	
1-18	Screw	3/8-16UNCx1 1/4	4	
1-19	Screw	1/4-20UNCx1/4	1	
1-20	Drive wheel		1	
1-21	Washer (B)		1	
1-22	Key	10x8x20	1	
1-23	Nut		1	
1-24	Spring washer	5/16	1	
1-25	Pulley cover (A)		1	
1-26	Non-step variator (A)		1	
1-27	Non-step variator (B)		1	
1-28	Lead screw		1	
1-29	Key	7x7x40	1	
1-30	Pulley cover (B)		1	
1-31	Motor mounting plate		1	
1-32	Spring washer	5/16	4	
1-33	Screw	5/16-18UNCx5/8	4	
1-34	Key	7x7x25	1	
1-35	Motor	2HP	1	
1-36	Gear box plate		1	

## 1. SAW BOW (B)

Index No.	Parts Name	Type	Q'ty	Note
1-37	gear box		1	
1-38	stud		1	
1-39	spring		1	
1-40	nut	1/2W-12	1	
1-41	adapter		1	
1-42	screw	1/4-20UNCx18	1	
1-43	set screw	1/4-20UNCx10	1	
1-44	bushing		1	
1-45	bearing	HK0810	2	
1-46	brush shaft		1	
1-47	screw	3/8-16UNCx1	1	
1-48	spring washer	3/8	1	
1-49	tension plate		1	
1-50	adjusting slide		1	
1-51	guide plate		1	
1-52	spring washer	1/4	6	
1-53	screw	1/4-20UNCx1	6	
1-54	spring washer	1/2	6	
1-55	bolt		1	
1-56	nipple	1/4	1	
1-57	screw	3/8-16UNCx2	3	
1-58	spring washer	3/8	3	
1-59	adjusting bolt		3	
1-60	spring pin	∅3x1	1	
1-61	collar		1	
1-62	blade tension screw		1	
1-63	set screw	5/16-18UNCx3/4	1	
1-64	hand wheel		1	
1-65	screw	1/2-W12x1-1/2	6	
1-66	variable belt	1422V400	1	
1-67	wire brush		1	
1-68	nut	5/16-18UNC	2	

2. BLADE GUIDE ARMS

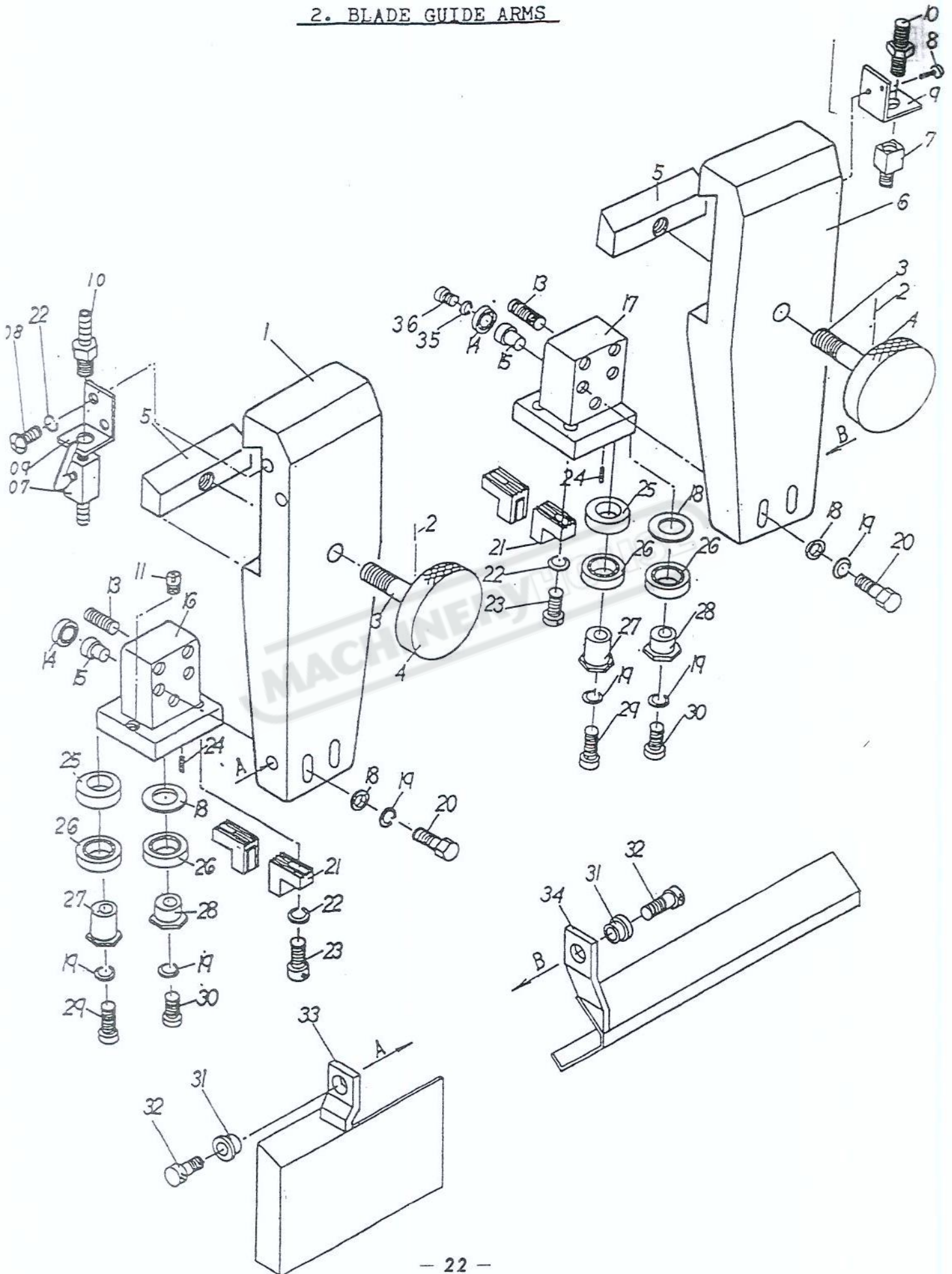

## 2. BLADE GUIDE ARMS

Index No.	Parts Name	Type	Q'ty	Note
2-1	guide arm (left)		1	
2-2	spring pin	∅3x30L (mm)	2	
2-3	bolt	1/2-20UNFx2 3/8	2	
2-4	knob		2	
2-5	clamping block		2	
2-6	guide arm (right)		1	
2-7	coolant valve		2	
2-8	screw	3/16-24UNCx3/8	4	
2-9	bracket		2	
2-10	fitting	PT 1/8"	2	
2-11	coolant nozzle	5/16"	2	
2-12	hose		2	
2-13	set screw	1/4-20UNCx1/2	6	
2-14	guide bearing	608ZZ	2	
2-15	bearing shaft		2	
2-16	guide seat (left)		1	
2-17	guide seat (right)		1	
2-18	washer	5/16	6	
2-19	spring washer	5/16	8	
2-20	screw	5/16-18UNCx11/4	4	
2-21	tungsten carbide blade guide		4	
2-22	spring washer	1/4	5	
2-23	screw	1/4-20UNCx1	4	
2-24	set screw	1/4-20UNCx1/4	2	
2-25	washer		2	
2-26	guide bearing	6202ZZ	4	
2-27	eccentric bushing(long)		2	
2-28	eccentric bushing (short)		2	
2-29	Screw	5/16-18UNCx38	2	
2-30	Screw	5/16-18UNCx25	2	
2-31	washer		2	
2-32	screw	1/4-20UNCx1/2	2	
2-33	Blade guard (L)		1	
2-34	Blade guard (R)		1	
2-35	Washer	3/16	2	
2-36	Screw	3/16-24UNC	2	

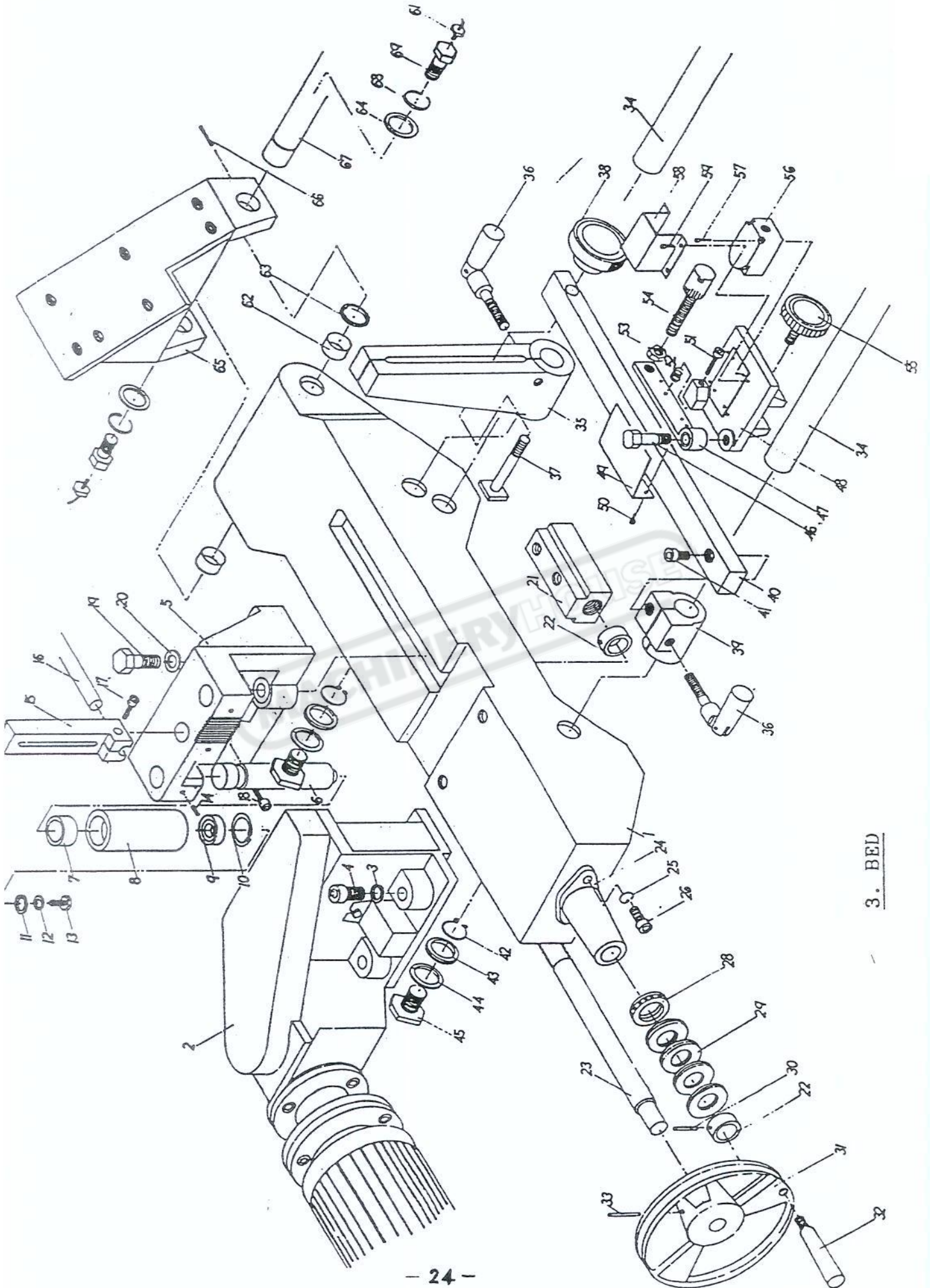

3. BED

## 3. BED (A)

Index No.	Parts Name	Type	Q'ty	Note
3-1	bed		1	
3-2	roller feed vice		1	
3-3	spring washer	5/8	2	
3-4	bolt	5/8-11UNCx2½	2	
3-5	movable vice casting		1	
3-6	shaft		3	
3-7	needle bearing	HK2820	3	
3-8	roller		3	
3-9	bearing	6202ZZ	3	
3-10	retainer	dia. 35	3	
3-11	washer		3	
3-12	spring washer	M8	3	
3-13	screw	1/4-20UNCx1/2	3	
3-14	set screw	5/16-18UNCx3/8	3	
3-15	nesting fixture		1	
3-16	pressing bar		1	
3-17	screw	5/16-18UNCx1¼	1	
3-18	screw	5/16-18UNCx1½	1	
3-19	bolt	5/8-11UNCx2½	2	
3-20	spring washer	M16	2	
3-21	lead screw nut		1	
3-22	collar		2	
3-23	vice lead screw		1	
3-24	lead screw seat		1	
3-25	spring washer		2	
3-26	screw		2	
3-28	thrust bearing	51205	1	
3-29	disk spring	dia. 25	8	
3-30	spring pin	dia. 6	1	
3-31	handwheel		1	
3-32	handle		1	
3-33	spring pin	ø6	1	
3-34	depth bar (length bar)		2	
3-35	adapter, right		1	
3-36	fastening bolt		2	
3-37	stud		1	

## 3. BED (B)

Index No.	Parts Name	Type	Q'ty	Note
3-38	knob		1	
3-40	cross slide		1	
3-41	screw	1/2W-12x1	1	
3-42	snap ring	S-30	2	
3-43	washer		2	
3-44	spring washer		2	
3-45	bolt	1/2W-12x1"	2	
3-46	pivot bolt		1	
3-47	rocker		1	
3-48	carriage		1	
3-49	cover		1	
3-50	screw	3/16-24UNCx1/2	2	
3-51	screw	3/8-16UNCx2	1	
3-52	spring		1	
3-53	nut	7/16-20UNF	1	
3-54	micro-adjust bolt		1	
3-55	fastening bolt		1	
3-56	limit switch		2	
3-57	screw	3/16-24UNCx1 1/4	6	
3-58	cover		1	
3-59	screw	3/16-24UNCx1/2	4	
3-61	nipple	1/4	2	
3-62	needle bearing	HK2820	2	
3-63	oil seal		1	
3-64	washer	1/2	2	
3-65	saw bow bracket		1	
3-66	set screw	1/4-20UNCx1/2	2	
3-67	pivot		1	
3-68	spring washer	1/2	2	
3-69	bolt	1/2	2	









# ANTI-Y JOJA WIRE DIAGRAM -1010JAY

